

## APOLLO

### *19 Light Cluster Pendant Antique Brass and Glass*

The Apollo Collection is a versatile and impactful design. The gathered glass effect of the 19 light pendant creates a dramatic cluster of light whereas the single pendant and wall light creates a simplified design aesthetic which works well in all interior spaces. Available in Butter Brass, Antqie Brass and Polished Chrome with a choice of either clear, opal or amber glass. Height is adjustable at the point of installation (100-260cm). Bulb not included; takes 19 x 40W max ES GLOBE. We recommend our BUL-E27-LED-20 bulb. Click here to shop. Dimmable when paired with suitable bulbs.



## SPECIFICATIONS:

Product code:	APO1975C
Measurements:	H min 100 - max 260 x Ø90cm
Lamp Replaceable:	Yes
Finish:	Antique Brass & Glass
Material:	Glass & Solid Brass
Cable Colour:	Braided Ivory
Shade Included:	Not Required
Primary Bulb Detail:	19 x 40w max ES Globe
Bulb Included:	Lamps not included
Recommended Lamp:	BUL-E27-LED-20
Suitable:	Indoor
Electrical Class:	Class I - Earthed
Nett Weight (kg):	12 kg ⚡ HIA

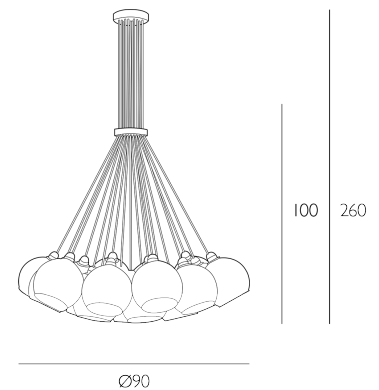

### ***Additional Information:***

This fitting, including its packaging, may not fit through entryways less than 65cm wide. Please check before placing your order | Please be aware this fitting weighs 12.0kg, please ensure you have adequate fixings and support to raise and install this fitting in the intended location