

STATION

Lamp Pendant Bespoke and Opal Glass

A classic and understated light large pendant which is carefully sprayed by hand in our Cotswolds based workshop. We are delighted to offer this fitting in either our beautiful palette of heritage inspired paint colours, or the classic polished chrome finish. The Station collection is an iconic range which has been handcrafted, using traditional methods of metal spinning. Height is adjustable at the point of installation (40-90cm).

Bulb not included; takes 1 x 60W max ES GLS. We recommend our BUL-E27-LED-16 bulb. [Click here to shop.](#)

Dimmable when paired with suitable bulbs.

Bespoke Orders

This is a fully customisable product, hand crafted in our workshop located in the Cotswolds. You can contact us directly discuss your unique requirements, or alternatively you can customise your product by using our product configurator to see your design before placing an order.

Returns

As our bespoke or customised fittings are made to your specific specification, these are not covered by our standard returns policy. We are unable to offer refunds after the initial 24 hour cooling off period. Please see our Terms and Conditions for more details. None of the above affects your statutory rights where goods are faulty or not as described.



SPECIFICATIONS:

Product code:	STN8199
Measurements:	H min40 - max90 x Ø37cm
Fixing Plate Dimensions:	H9.6 x Ø9cm
Lamp Replaceable:	Yes
Finish:	Bespoke & Opal Glass
Material:	Glass & Metal
Shade Included:	Not Required
Primary Bulb Detail:	1 x 60w max ES GLS
Bulb Included:	Lamp not included
Recommended Lamp:	BUL-E27-LED-16
Suitable:	Indoor
Electrical Class:	Class 2 - Double Insulated
Nett Weight (kg):	1.2 kg

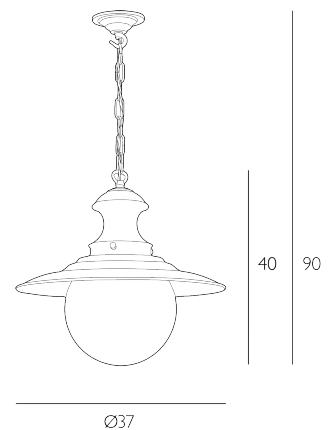

Additional Information:

Supplied with 120cm of cable

www.davidhuntlighting.co.uk

sales@davidhuntlighting.co.uk

01295 672 628