

UPTON

Pendant Polished Chrome and Opal Glass

Our Upton large 1 light pendant features polished chrome metal work with matching silver braided cotton cable complimented with a simple opal glass design, perfect for modern living. The Upton Pendant is also available in black or antique brass metalwork with a choice of clear or opal glass in both large and small sizes.

Height is adjustable at the point of installation (44-94cm).

Bulb not included; takes 1 x 60W max ES GLS. We recommend our BUL-E27-LED-I6 bulb. [Click here to shop.](#)

Dimmable when paired with suitable bulbs.



SPECIFICATIONS:

Product code:	UPT81500
Measurements:	H min44 - max94 x Ø30cm
Fixing Plate Dimensions:	H65 x Ø13cm
Lamp Replaceable:	Yes
Finish:	Opal Glass & Polished Chrome
Material:	Glass & Metal
Cable Colour:	Braided Silver
Shade Included:	Not Required
Primary Bulb Detail:	1 x 60w max ES GLS
Bulb Included:	Lamp not included
Recommended Lamp:	BUL-E27-LED-I6
Suitable:	Indoor
Electrical Class:	Class I - Earthed
Nett Weight (kg):	1.7 kg

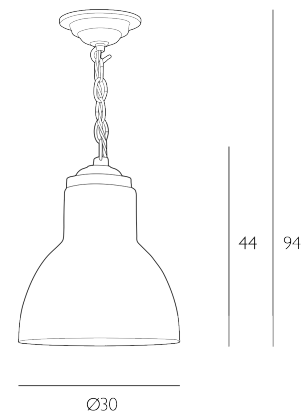

Additional Information:

Supplied with 100cm of cable